

JACK

快速服务100%

包缝机 Overlock Sewing Machine

C3系列 C3 Series

产品使用说明书 Product Users' Manual

使用说明和零件样本下载地址:

PLEASE DOWN LOAD THE MANUAL AND SPARE PARTS FROM THE FOLLOWING WEBSITE:

ÇãÑİÇÁ Êíáëä äêëÊ ÇãËÛäëäÇÊ ëä×Û ÇãËËËäë äë ÇãäëäÛ ÇãËÇäë:

POR FAVOR DESCARGAR EL MANUAL Y LIBRO DE PARTES Y REPUESTOS LO SIGUIENTE

EN SITIO WEB:

Пожалуйста, загрузите инструкцию по эксплуатации и деталировку (список

запасных частей) со следующего вебсайта:

http://download.chinajack.com

产品标准代号: QB/T1515-2005

Standard code of the products: QB/T1515-2005

杰克缝纫机
JACK SEWING MACHINE
HTTP://WWW.CHINAJACK.COM

杰克缝纫机股份有限公司
NEW JACK SEWING MACHINE CO.,LTD.

- 公司地址(Address of Company):
台州市椒江区机场南路15号
No. 15 Rd Airport South, Jiaojiang District Taizhou City, Zhejiang, P.R.C
- 国内销售部(Domestic Trade Department):
电话(TEL): 0086-0576-88177788 88177789
传真(FAX): 0086-0576-88177758
- 国际贸易部(International Trade Department):
电话(TEL): 0086-0576-88177782 88177774
传真(FAX): 0086-0576-88177787
- 免费售后服务电话: 8008576858
http://www.chinajack.com
- 资料如有更改,恕不另行通知,以实样为准。
You will be not informed if the file has been revised. Please set sample as standard
2019年11月版



请您扫下杰克服务号

穿线的方法 Threading

打开压脚杆及机盖(三处),把机上原有的线与缝绉用线绑在一起

Open three covers, Sewing the presser foot aside kont the preset thread and the thread being used together to thread the machine

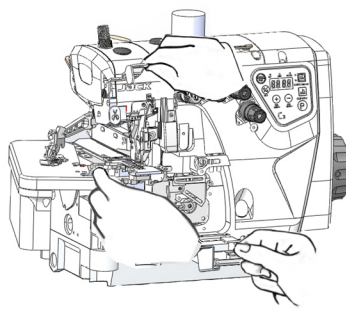

针线 Needle thread

将线拉到针眼前,剪掉结头再次穿好针线,若机上原来没有线请参照穿线图正确进行穿线,弯针线,线拉出接头后,用剪刀剪齐接头

Trim the knots off neatly before passing through the needle to rethread, Make sure the machine is thraded correctly by referring to threading digram, looper thread Trim the knots off neatly after passing through the eye of the looper

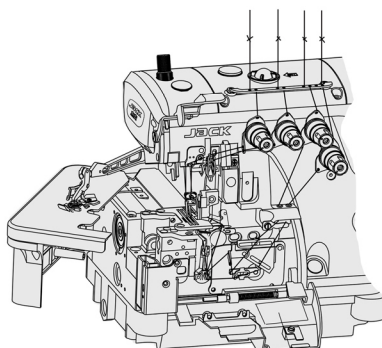

过线图 Threading diagram

压脚压力的调节

Adjusting the presser foot pressure

压脚压力的调节,松开螺母①,调节螺母②
Loosen adjusting nut① and then turn adjusting nut② to adjusting the presser foot pressure, It should be as light as possible in the feed situation when the steady state was obtained

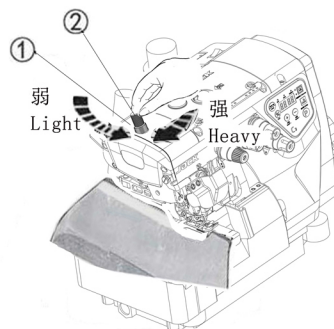

弱 Light 强 Heavy

缝纫机的清扫 Cleaning the machine

缝纫机的清扫,以针板槽及送布牙周围为主
Mainly the slots of the needle plate and the feed rows should be of cleaned

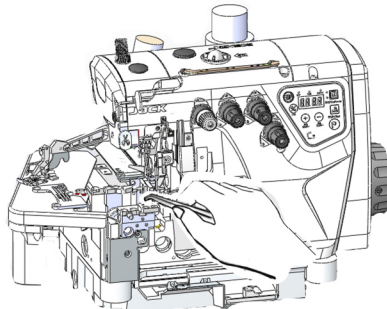

换针

Replacing the needle

准确辨认针的前后,请将针凹向着后方,即背向操作者进行安装,针要牢固的插到最深处
Check the needle carefully to see that the scarf is turned to the rear of the machine
Insert the needle to the proper depth and fasten securely

标准使用针:
风琴DCX27
Standard needle
Organ DCX27

手动供油 Manual Lubrication

手动供油是在缝绉机最初开始使用时,或者相当一段时间未使用时,请供给2-3滴油

Apply 2 or 3 drops of oil by hand when the machine is used for the first time or has been left unuse for some time

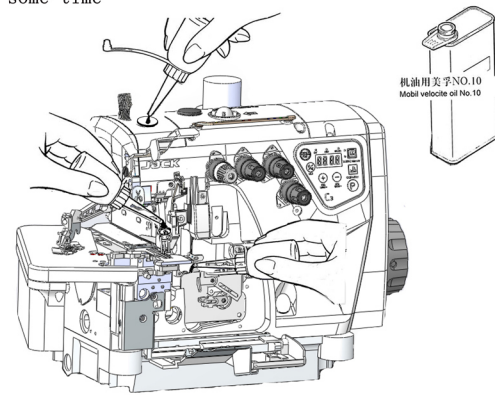

给HR装置供油

Filling the HR device with silicon oil

为了防止布纤维或线被切断,请尽早给HR装置供油

主:关于购买硅脂油,请咨询缝绉机代销售店或本公司营业厅联系
illing the device with oil before it is too low in order prevent needle thead breakage and fabric damage: Use recomended silicon oil

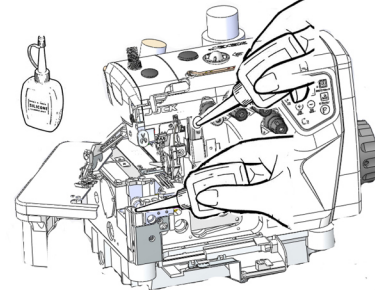

差动比的调节

Adjusting the differential feed ratio

差动比的调节,松开螺母①,调节螺母②
Loosen the adjusting nut① and turn the adjusting nut② to adjusting the differential feed ratio

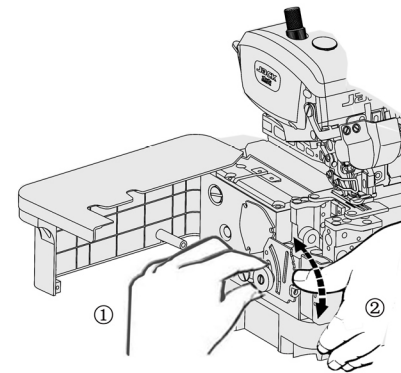

针脚长度的调节

Adjusting the thread tension

1. 摁住按钮,旋转手轮,按钮会陷进更深处
2. 这时边摁住按钮边转动手轮,使校准标记号对准所希望的数值

1. While pressing the push button, turn the hangwheel to seek the position at which the hangwheel and set the desired scale to push button goes further into the depth
2. Then, keeping the push button pressed turn the aligning mark

注:针脚长度的调节务必请在调节差动比之后进行
Note: Stitch length adjusting must only be made after the differentail feed ratio has been changed

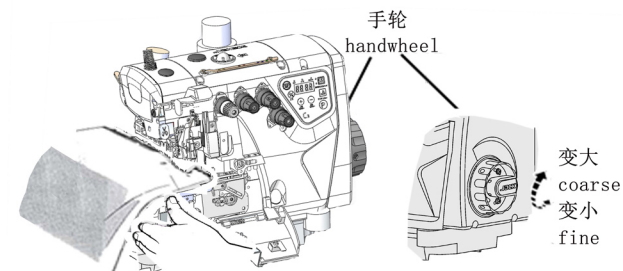

变大 coarse
变小 fine

为了安全

对于缝绉机本身各种重量,我们充分考虑到它的安全性,请遵照基本的操作方法,安全的进行工作

- 拆除为保证安全设置的装置的零件的情况下使用,是非常危险的,请绝对不要拆除后使用
- 缝绉机在使用时,请不要在缝绉机台板上放置工具及缝绉时不必要的物品
- 在缝绉机进行检修、调节、清扫、穿线换针等工作时为防止发生事故,务必切断电源,在确认即使踩下缝绉机踏板,缝绉机也不转动后,再进行操作

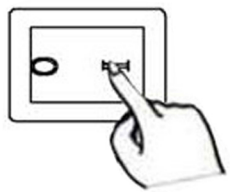

OBSERVE THESE SAFETY PRECAUTIONS

Though Our takes the utmost care to produce safe sewing machines and devices, operstors should follow these basic safety rules

- To prevent accident, do not remove safety devices or parts while operating the machine
- Do not leave tools or other unnecessary objects on the machine table while operating the machine
- Before maintenance, adjusting, cleaning, thrashing or replacing the needle, and to prevent accidents be sure the power is the power is turned off, Check that the machine will not operate the pedal is pressed

- 在离开缝绉机台时,务必关掉电源
- 停电时请务必关掉电源
- 为了总是安全的使缝绉机运转良好,日常的检点是不可缺少的,请予以注意
- Turn the power off before leaving machine table
- In the event of a power failure, be sure to turn the machine off
- To guarantee the machine always works well and safety, pay more attention to the daily spot check

台板加工图

Schematic digram of the machine table

请参照下图进行台板加工
Cut the table referring to the diagram

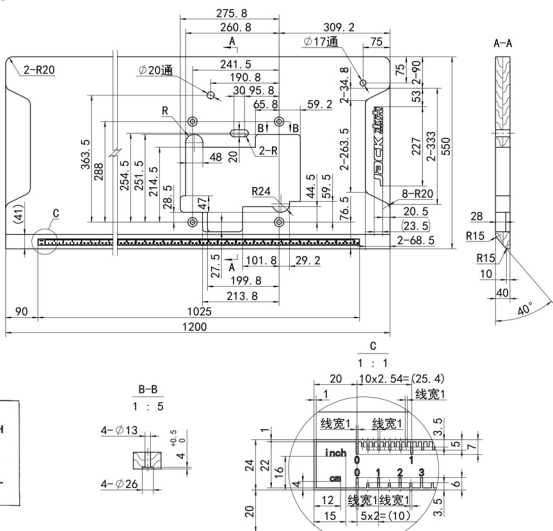

供油 Lubrication

加油时油量使油面处于H线与L线之间为好,当油面低于L线时,就要及时补充机油

After filling the oil pan, the top of and indicator should lie between (H) and (L) line add oil, when the oil level indicators reaches or goes below (L)

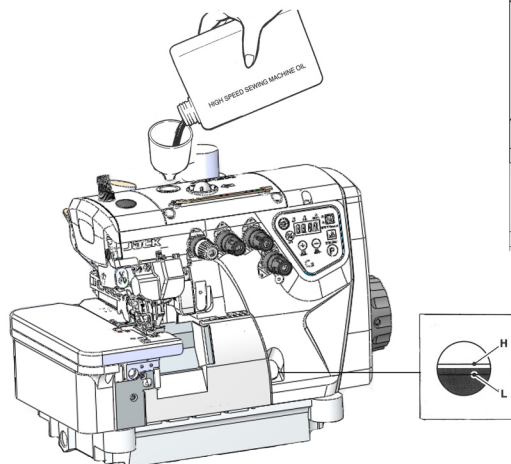

线状态的调节
Adjusting the thread tension
线张力状态的调节，针线调节请用螺帽①，上弯针线调节请用螺帽②，下弯针线调节螺帽请用螺帽③进行调节
Make tension adjustments with the needle thread knob①, the upper looper knob② and the lower looper knob③

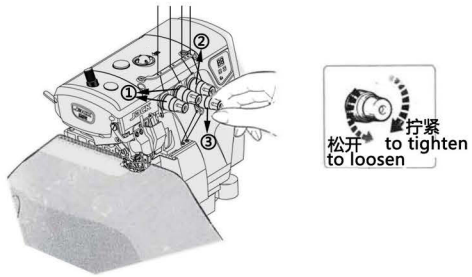

检查机油的循环
Checking the oil circulation

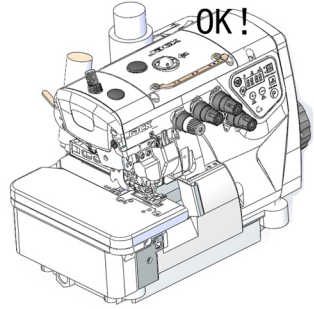

换机油 Replacing the oil
机油的更换，请在使用开始1个月后更换一次，然后，请6个月更换一次
Replacing the oil one month after the first use and every six months thereafter

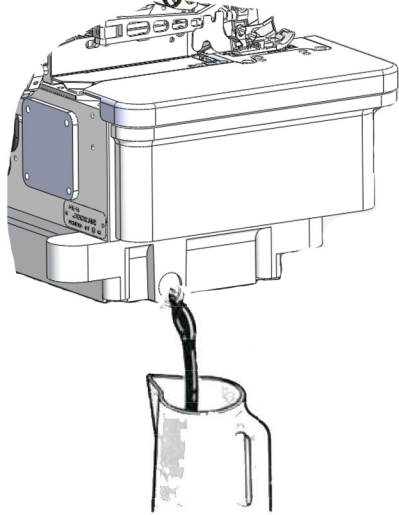

检查油质量，更换油芯
Checking and replacing the oil filler
机油每6个月检查并更换
Check and replace the oil filler every six months

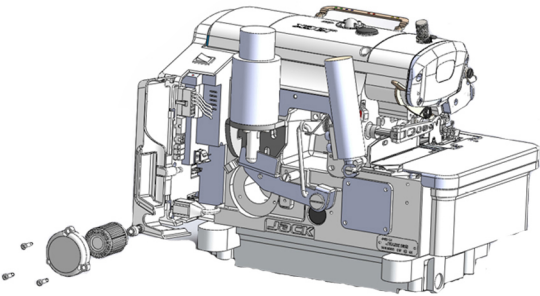

工业缝纫机安全使用注意事项
Notes for safe use of industrial sewing machines

1. 必须遵守基本措施;
Basic measures must be observed.
2. 必须经过专业培训, 对缝纫机设备性能;
Pass the specialized training and master sewing machine equipment performance.
3. 使用前应检查所有安全装置;
All safety devices should be checked before use.
4. 在安装机针、更换机针、压脚、针板、送布牙、弯针、旋梭或修理时, 应立即关闭电源;
When installing needle, and changing needle, presser foot, plate, feed dog, bent needle, hook or repairing, the power supply should be turned off immediately.
5. 离开缝纫机或工作场所时应关闭电源;
Power should be turned off when leaving the sewing machine or workplace.
6. 使用离合马达时, 要等待马达完全停止后再进行;
When using the clutch motor, please wait until the motor stops completely.
7. 缝纫机及附属装置使用的机油, 润滑油等液体流入眼睛或沾到皮肤上应立即清洗;
The machine oil and other liquids used in sewing machines and ancillary devices should be cleaned immediately when they are put into eyes or touch skin.
8. 禁止用手触摸缝纫机通电时的零件或装置;
Do not touch the parts or devices when the machine is powered by hand.
9. 有关工业用平缝机与包缝机的修理、改造、主要机构的调整由专门技术人员来进行;
The repair, renovation and adjustment of the main mechanisms of the relevant industrial sewing machines and overseers shall be carried out by specialized technicians.
10. 一般的维修保养由专人进行;
General maintenance is carried out by specially assigned persons.
11. 在电气方面的修理应在电气技术员的监督指导下进行;
Electrical repairs should be performed under the supervision and direction of the electrical technician.
12. 缝纫机使用期间应定期清扫;
The machine should be cleaned regularly during operation.
13. 为了正常安全运转, 应安装地线, 同时应在不受高频焊接机等强噪声源影响的环境下使用;
In order to operate normally and safely, ground lines should be installed, and they should be used in an environment free from strong noise sources such as high frequency welding machine.
14. 电源插头应由专人安装;
Power plug should be installed by specially assigned person.
15. 工业用平缝机、包缝机在指定用途以外不能使用。
Industrial lockstitch sewing machine and overlock sewing machine can not be used except the designated use.

环保要求 Environmental requirements

1. 使用过程中产生的废油及其他废弃物请根据当地环保的要求进行合理的处置。
Please dispose the waste oil and other waste products properly according to local environmental protection requirements.
2. 请在使用完后及时关闭电源, 减少电能的消耗。
Please turn off the power after use to reduce power consumption.
3. 请在说明书要求的电压及环境下使用, 已延长产品的使用寿命, 减少废弃物的产生。
Please use under the voltage and environment required in the manual to extend the service life of the product and reduce waste generation.
4. 机器报废后请勿将本机器及其附件作为普通的生活垃圾处理。请遵守本设备及其附件处理的本地法令, 并支持回收行动。
Do not treat the machine and its accessories as ordinary household garbage after being scrapped. Please comply with local laws governing the disposal of the equipment and its accessories and support recycling operations.

下刀片的更换 Replacing the lower knife 安装下刀片 Install the lower knife

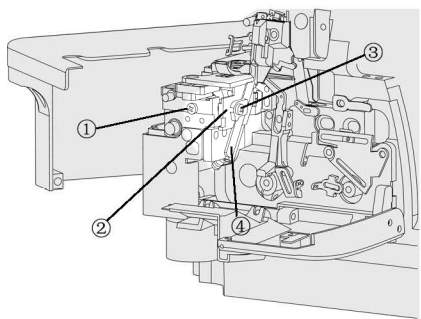

- ① 松开螺丝 Loosen the screw
- ② 把下刀架推向左边, 用螺丝①暂时固定
Temporarily screw ① after sliding the lower holder to the left
- ③ 松开螺丝 Loosen the screw
- ④ 取下下刀片 Remove the lower knife

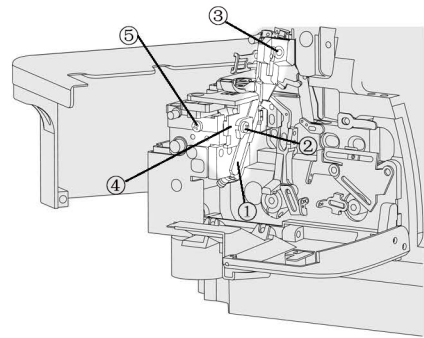

- ① 装入下刀片 Insert the lower knife
- ② 拧紧螺丝 Tighten the screw
- ③ 转动手轮将上刀移动对准如图所示位置
Turn the handwheel as the drawing on the right figure
- ④ 松开螺丝⑤, 下刀架则向右移动
Loosening the screw ⑤ makes the lower knife holder slide to the right
- ⑤ 拧紧螺丝 Tighten the screw

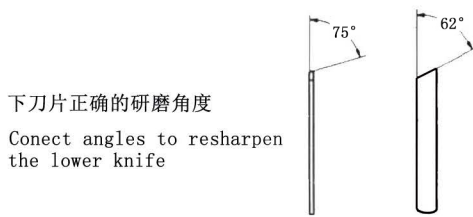

下刀片正确的研磨角度
Connect angles to resharpen the lower knife

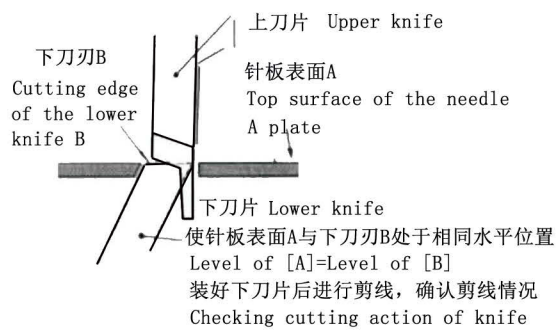

C3调整基准表

机型	机针高度	下弯针引量	上弯针				二重环引量	送布				速度
			出量	高度	弯针架左右位置	上弯针座安装方向		送布倾斜度	送齿高度	辅助送齿高度差	送布偏心率	
C3-3-02/233	10.5	3.8	4.4-4.7	10.8	14.5	左	—	针板上面水平	0.8	0.5	0.35-2	5800
C3-4-M03/333	10.5	3.8	5.4-5.7	11.5	13.5	右	—	针板上面水平	0.8	0.5	0.35-2	
C3-4-M03/333/H/M	11.5	3.8	3.7-3.9	11.5	13.5	右	—	针板上面水平	0.8	0.5	0.35-2	
C3-5-03/233	10.5	3.8	4.4-4.7	10.8	14.5	左	1.5	针板上面水平	0.8	0.5	0.35-2	
C3-5-03/333	10.5	3.8	4.4-4.7	10.8	14.5	左	1.5	针板上面水平	0.8	0.5	0.35-2	
C3-5-A04/435	11.9	4.2	5.0-5.3	12	14.5	左	1.7	针板上面水平	1.1	0.5	0.35-2	